



MOD

modular lounge

Configuration sheet



SOVEREIGN
INTERIORS

SCHIENALE MEDIO
MEDIUM BACK

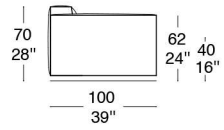
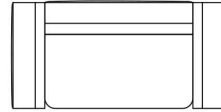
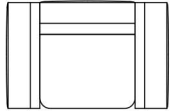

MOR 01

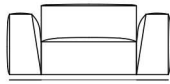

150
59"

MOR 02

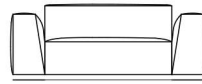

180
71"

MOR 03

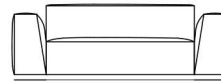

200
79"

SCHIENALE MEDIO
MEDIUM BACK

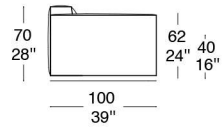
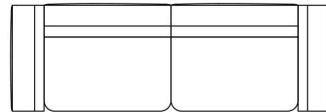

MOR 04

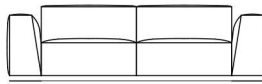

240
94"

MOR 05

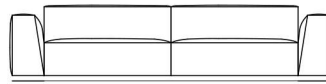

300
118"

MOR 06

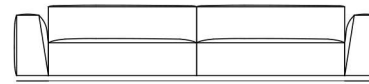

340
134"

SCHIENALE ALTO
HIGH BACK

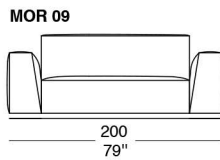
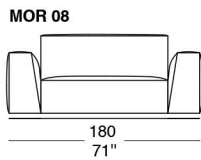
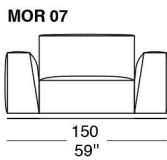
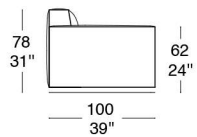
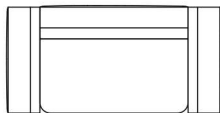
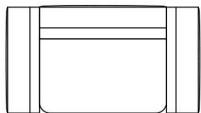
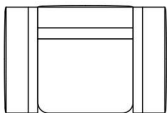

SCHIENALE ALTO
HIGH BACK

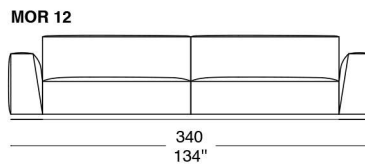
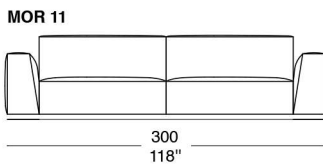
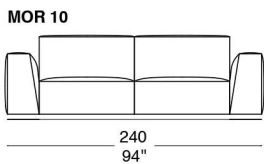
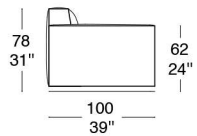
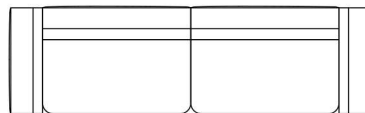
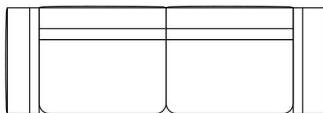
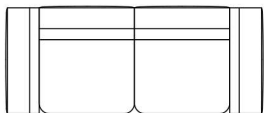

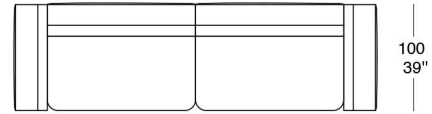
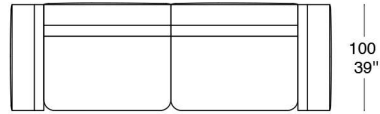
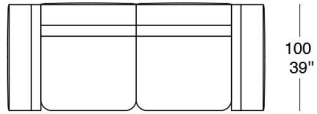

SCHIENALE SX ALTO/MEDIO
LEFT HIGH/MEDIUM BACK

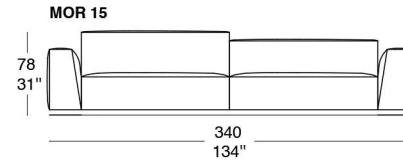
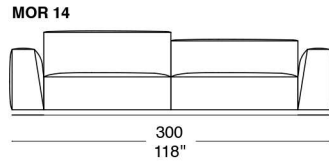
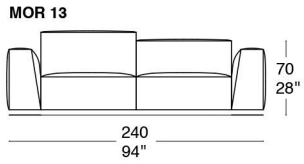

SCHIENALE DX MEDIO/ALTO
RIGHT MEDIUM/HIGH BACK

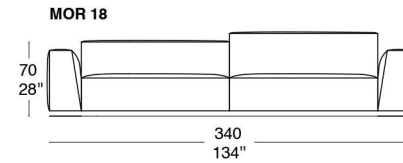
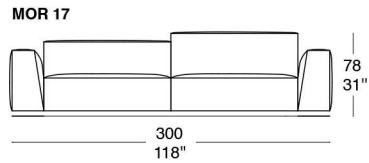
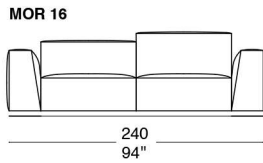

SCHIENALE MEDIO SX
LEFT MEDIUM BACK

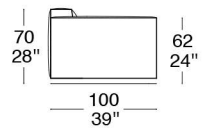

MOR 19

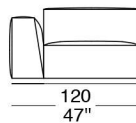

MOR 20

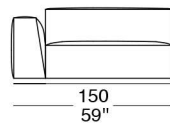

MOR 21

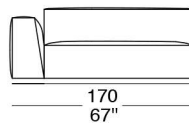

SCHIENALE MEDIO DX
RIGHT MEDIUM BACK

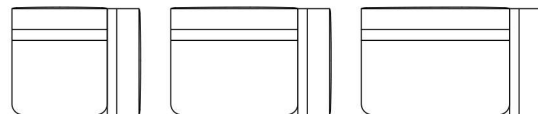

MOR 22

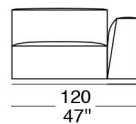

MOR 23

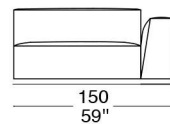

MOR 24

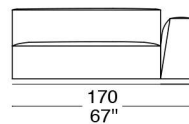

SCHIENALE ALTO SX
LEFT HIGH BACK

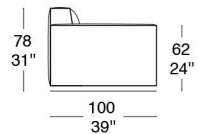
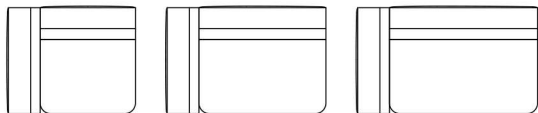

MOR 25

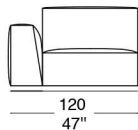

MOR 26

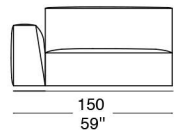

MOR 27

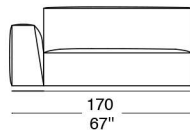

SCHIENALE ALTO DX
RIGHT HIGH BACK

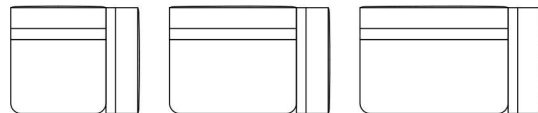

MOR 28

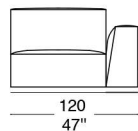

MOR 29

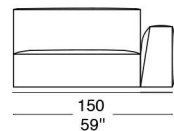

MOR 30

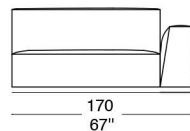

MOR 35

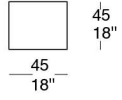

MOR 36

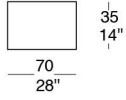

MOR 37

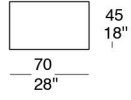

MOR 38

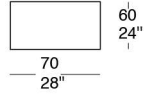

MOR 39

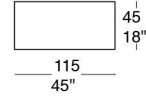

MOR 45

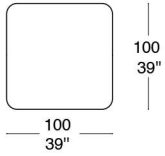

MOR 46

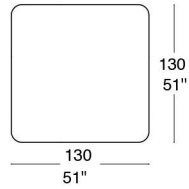

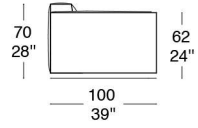
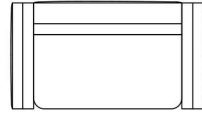
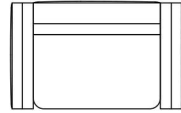
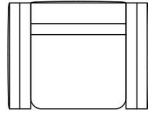

MOR 50

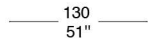
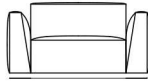

MOR 51

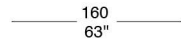

MOR 52

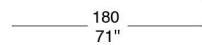
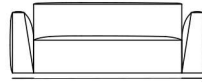

SCHIENALE MEDIO
MEDIUM BACK

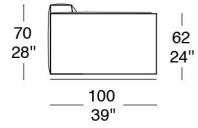
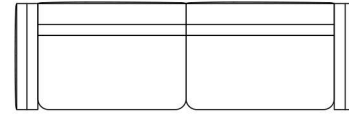
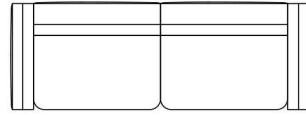
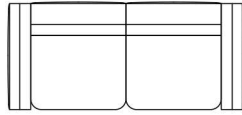

MOR 53

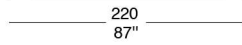
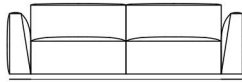

MOR 54

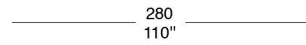
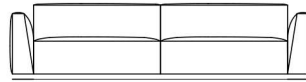

MOR 55

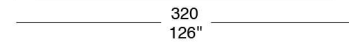

SCHIENALE MEDIO
MEDIUM BACK

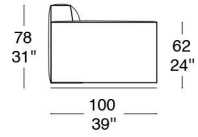
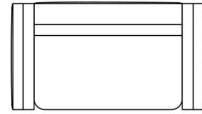
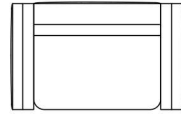
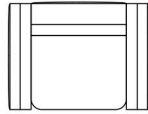

MOR 56

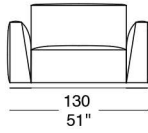

130
51"

MOR 57

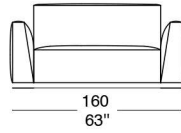

160
63"

MOR 58

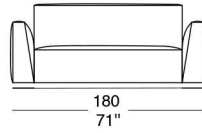

180
71"

**SCHIENALE ALTO
HIGH BACK**

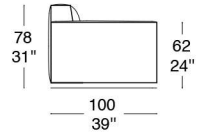
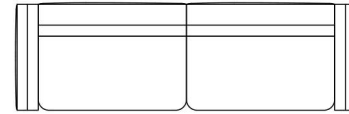
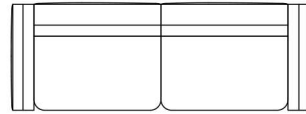
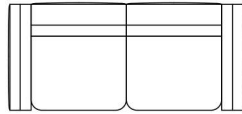

MOR 59

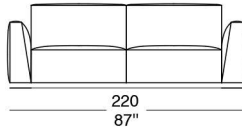

220
87"

MOR 60

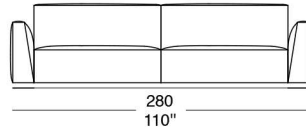

280
110"

MOR 61

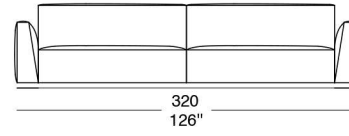

320
126"

**SCHIENALE ALTO
HIGH BACK**

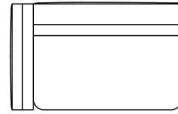
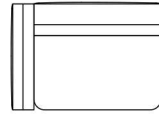
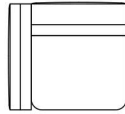

MOR 62

MOR 63

MOR 64

SCHIENALE MEDIO SX
LEFT MEDIUM BACK

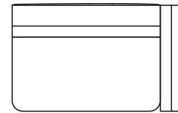
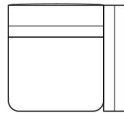
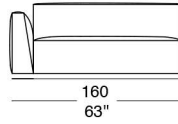
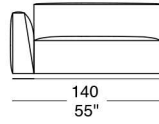
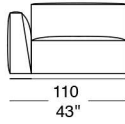
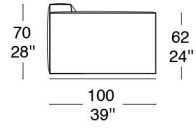

MOR 65

MOR 66

MOR 67

SCHIENALE MEDIO DX
RIGHT MEDIUM BACK

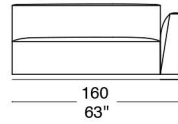
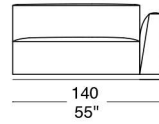
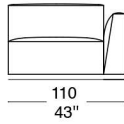

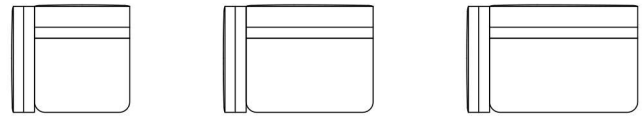
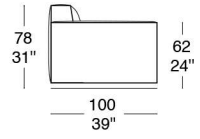

MOR 68

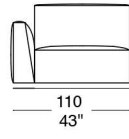

MOR 69

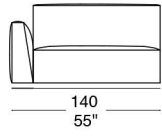

MOR 70

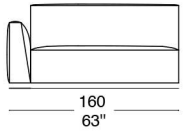

SCHIENALE ALTO SX
LEFT HIGH BACK

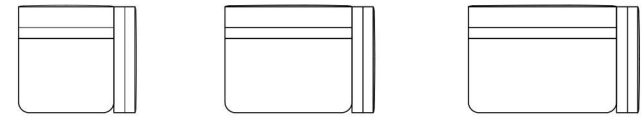

MOR 71

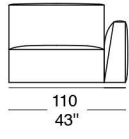

MOR 72

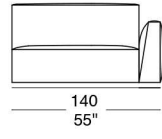

MOR 73

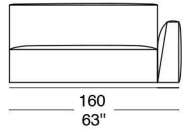

SCHIENALE ALTO DX
RIGHT HIGH BACK

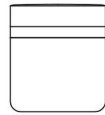
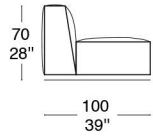

MOR 83



90
35"

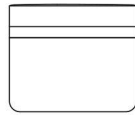

MOR 84

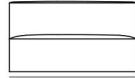

120
47"

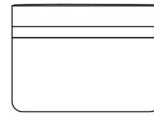

MOR 85



140
55"

SCHIENALE MEDIO
MEDIUM BACK

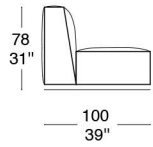

MOR 86

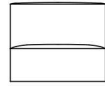

90
35"

MOR 87

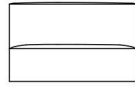

120
47"

MOR 88

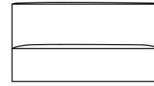

140
55"

SCHIENALE ALTO
HIGH BACK

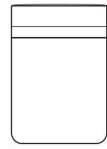
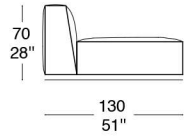

MOR 92

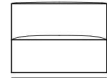

90
35"

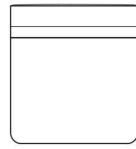

MOR 93

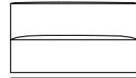

120
47"

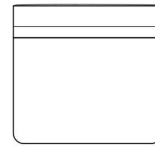

MOR 94

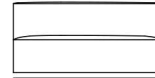

140
55"

SCHIENALE MEDIO
MEDIUM BACK

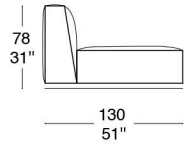

MOR 95

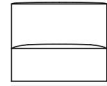

90
35"

MOR 96

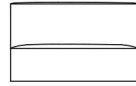

120
47"

MOR 97

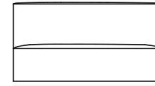

140
55"

SCHIENALE ALTO
HIGH BACK

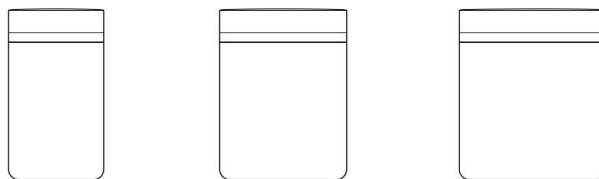

MOR 101

MOR 102

MOR 103

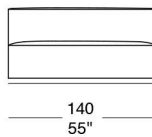
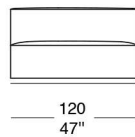
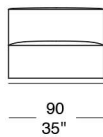
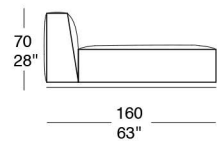

SCHIENALE MEDIO
MEDIUM BACK

MOR 104

MOR 105

MOR 106

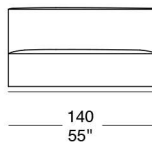
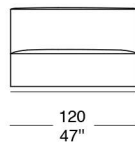
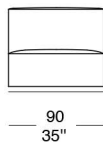
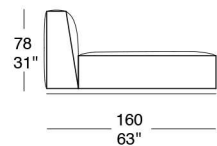

SCHIENALE ALTO
HIGH BACK

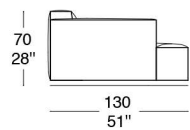
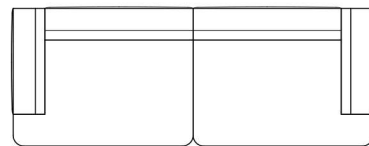
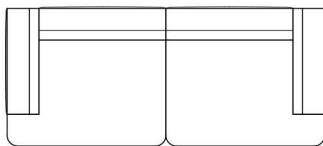
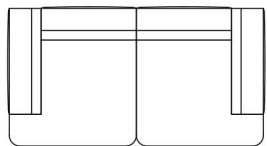

MOR 110

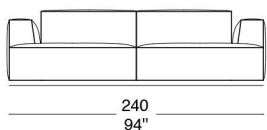

MOR 111

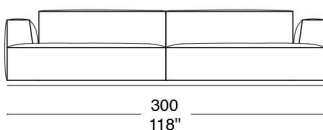

MOR 112

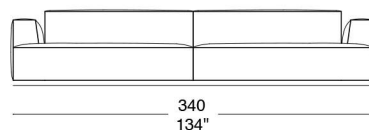

SCHIENALE MEDIO
MEDIUM BACK

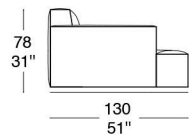

MOR 113

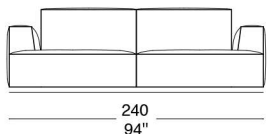

MOR 114

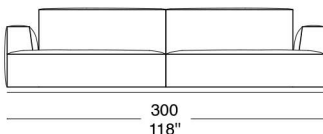

MOR 115

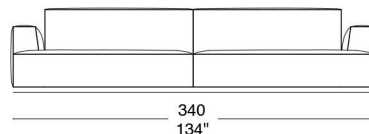

SCHIENALE ALTO
HIGH BACK

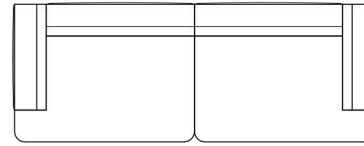
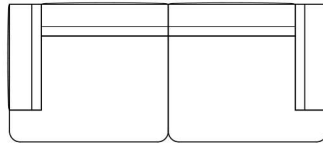
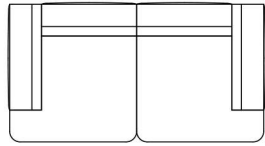

MOR 116

MOR 117

MOR 118

SCHIENALE SX ALTO/MEDIO
LEFT HIGH/MEDIUM BACK

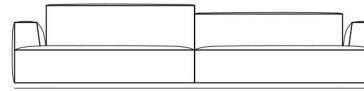
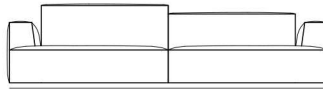
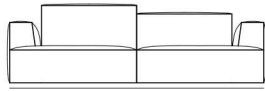

240
94"

300
118"

340
134"

MOR 119

MOR 120

MOR 121

SCHIENALE DX MEDIO/ALTO
RIGHT MEDIUM/HIGH BACK

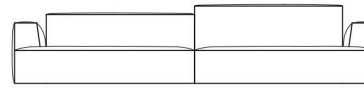
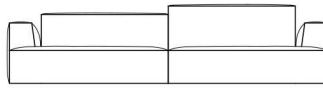
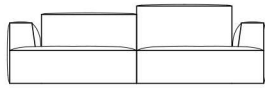

240
94"

300
118"

340
134"

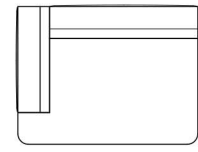
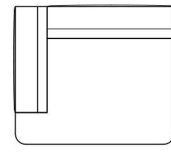
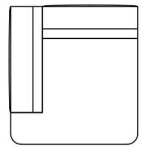
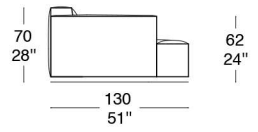

MOR 122

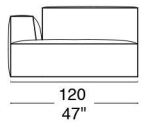

MOR 123

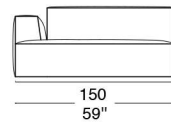

MOR 124

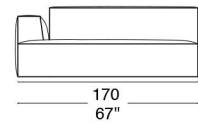

SCHIENALE MEDIO SX
LEFT MEDIUM BACK

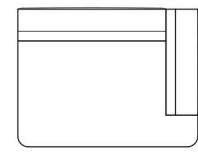
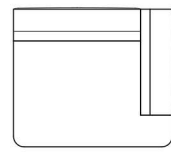
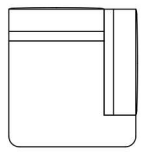

MOR 125

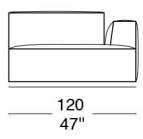

MOR 126

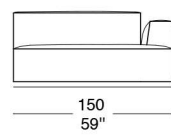

MOR 127

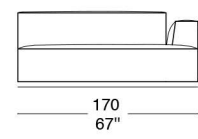

SCHIENALE MEDIO DX
RIGHT MEDIUM BACK

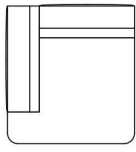
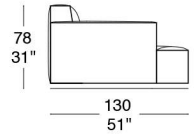

MOR 128

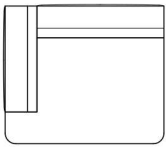
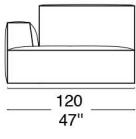

MOR 129

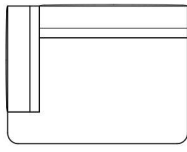
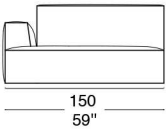

MOR 130

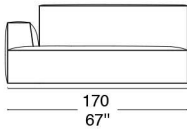

SCHIENALE ALTO SX
LEFT HIGH BACK

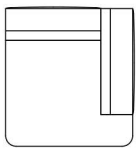

MOR 131

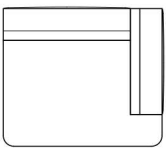
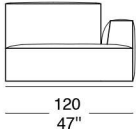

MOR 132

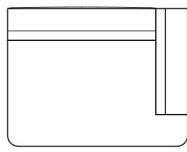
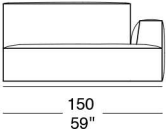

MOR 133

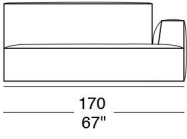

SCHIENALE ALTO DX
RIGHT HIGH BACK

MOR 140



$\frac{30}{12''}$

62
24''



$\frac{100}{39''}$

BRACCIOLO BASSO
LOW ARM

MOR 141



$\frac{30}{12''}$

70
28''



$\frac{100}{39''}$

BRACCIOLO MEDIO
MEDIUM ARM

MOR 142



$\frac{30}{12''}$

78
31''



$\frac{100}{39''}$

BRACCIOLO ALTO
HIGH ARM

MOR 143



$\frac{20}{8''}$

62
24''



$\frac{100}{39''}$

BRACCIOLO BASSO
LOW ARM

MOR 144



$\frac{20}{8''}$

70
28''



$\frac{100}{39''}$

BRACCIOLO MEDIO
MEDIUM ARM

MOR 145



$\frac{20}{8''}$

78
31''



$\frac{100}{39''}$

BRACCIOLO ALTO
HIGH ARM

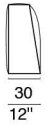

70
28"

MOR 149

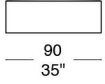

MOR 150

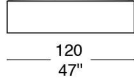

MOR 151

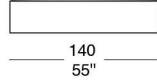

SCHIENALE MEDIO
MEDIUM BACK

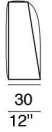

78
31"

MOR 152

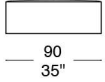

MOR 153

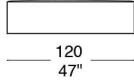

MOR 154

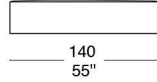

SCHIENALE ALTO
HIGH BACK



70
28"

MOR 158

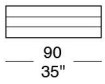

MOR 159

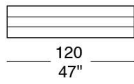

MOR 160

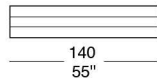

SCHIENALE BIFACCIALE MEDIO
MEDIUM BIFACIAL BACK



78
31"

MOR 161

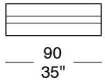

MOR 162

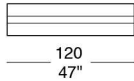

MOR 163

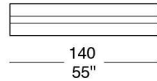

SCHIENALE BIFACCIALE ALTO
HIGH BIFACIAL BACK

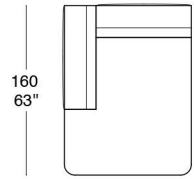

SCHIENALE MEDIO SX
LEFT MEDIUM BACK

MOR 172

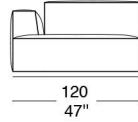

70
28"

MOR 173

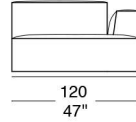

SCHIENALE MEDIO DX
RIGHT MEDIUM BACK

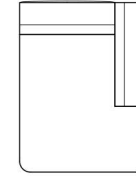

160
63"

SCHIENALE ALTO SX
LEFT HIGH BACK

MOR 174

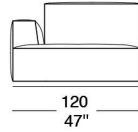

78
31"

MOR 175

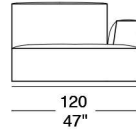

SCHIENALE ALTO DX
RIGHT MEDIUM BACK

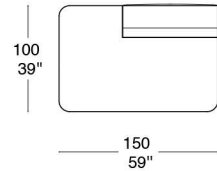

SCHIENALE MEDIO SX
LEFT MEDIUM BACK

MOR 178

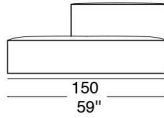

70
28"

MOR 179

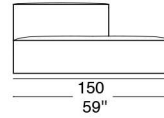

SCHIENALE MEDIO DX
RIGHT MEDIUM BACK

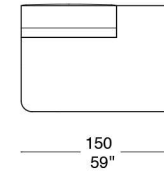

100
39"

SCHIENALE ALTO SX
LEFT HIGH BACK

MOR 180

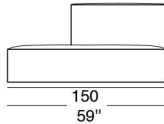

78
31"

MOR 181

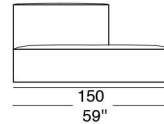

SCHIENALE ALTO DX
RIGHT MEDIUM BACK

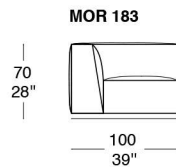
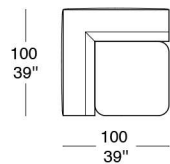

SCHIENALE MEDIO
MEDIUM BACK

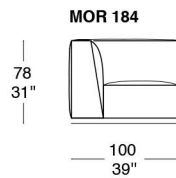

SCHIENALE ALTO
HIGH BACK

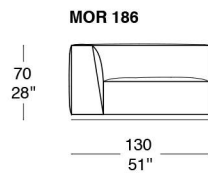
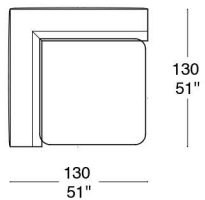

SCHIENALE MEDIO
MEDIUM BACK

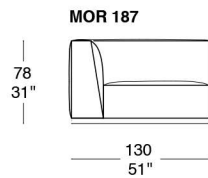

SCHIENALE ALTO
HIGH BACK

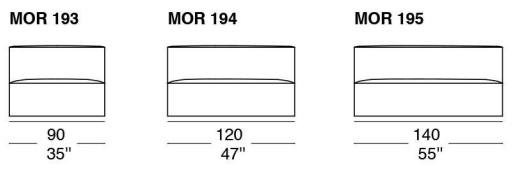
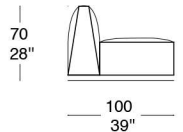

SCHIENALE BIFACCIALE MEDIO
MEDIUM BIFACIAL BACK

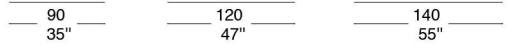
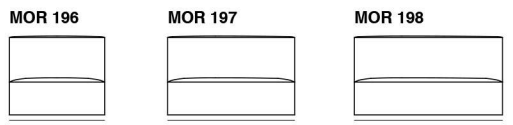
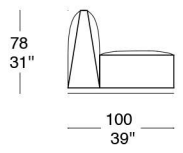

SCHIENALE BIFACCIALE ALTO
HIGH BIFACIAL BACK

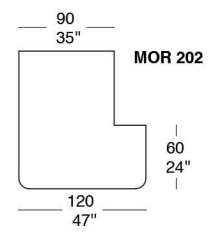
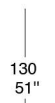
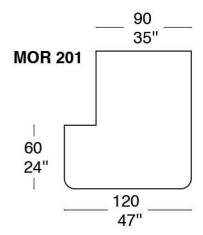
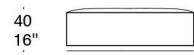
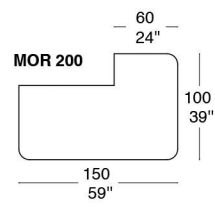
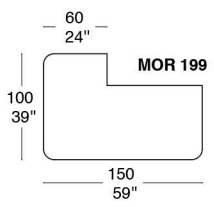
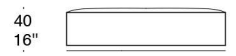

40
16"

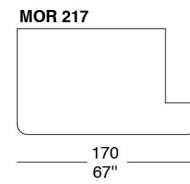
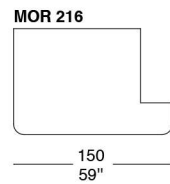
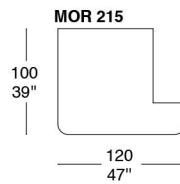
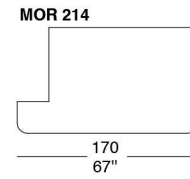
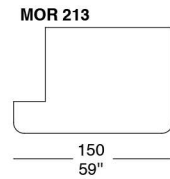
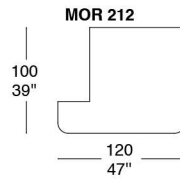
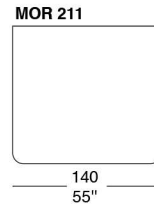
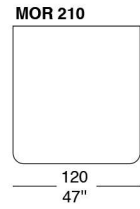
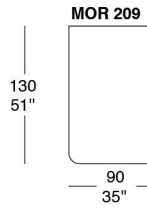
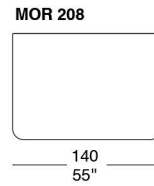
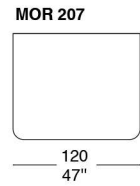
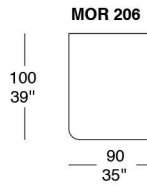
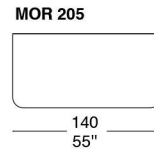
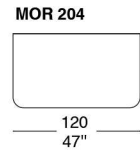
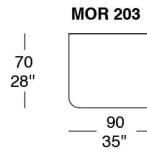

62
24"



70
28"

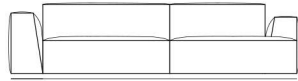

62
24"

SCHIENALE MEDIO
MEDIUM BACK

MOR 221

160
63"

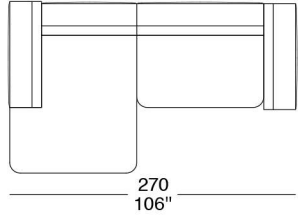

100
39"

MOR 222

160
63"

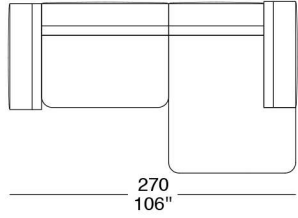

270
106"

270
106"

62
24"



70
28"



62
24"

SCHIENALE MEDIO
MEDIUM BACK

MOR 223

160
63"

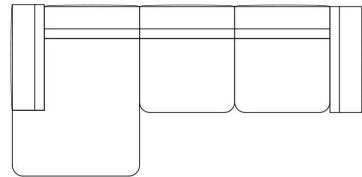

100
39"

MOR 224

160
63"

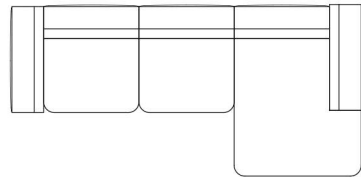

330
130"

330
130"

**BRACCIOLO ALTO
SCHIENALE MEDIO/ALTO**
*HIGH ARM
MEDIUM/HIGH BACK*

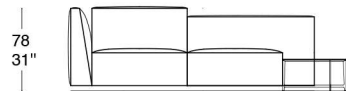

**BRACCIOLO ALTO
SCHIENALE ALTO/MEDIO**
*HIGH ARM
HIGH/MEDIUM BACK*

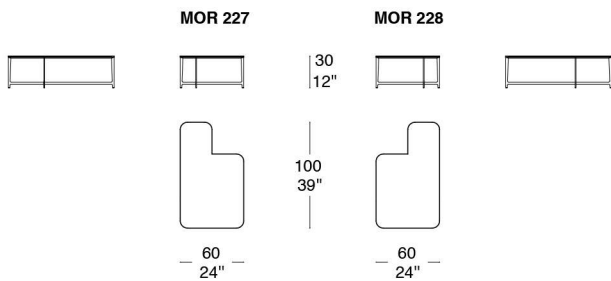
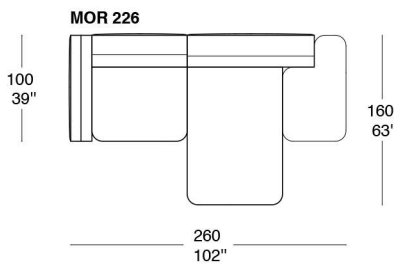
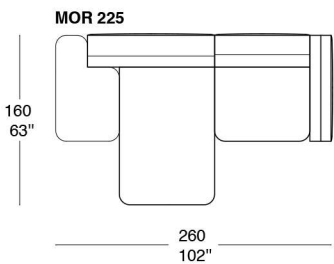

MOR 229

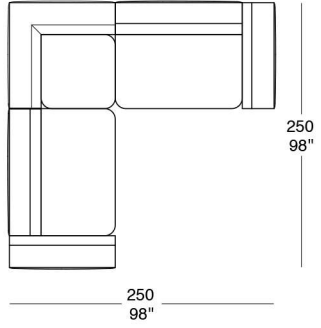

MOR 230

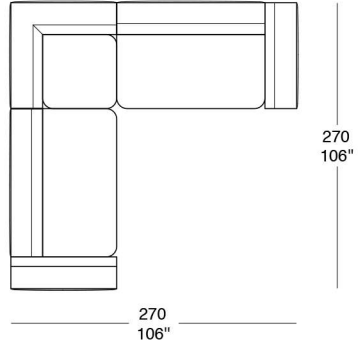

MOR 231

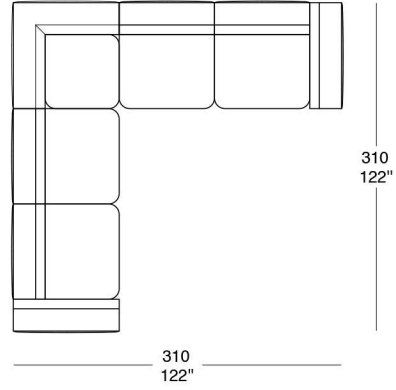

MOR 232

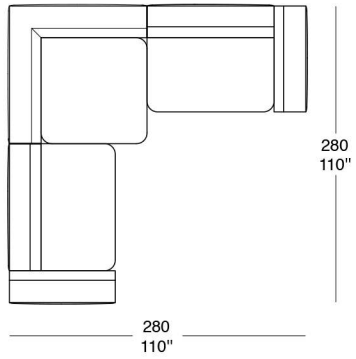

MOR 233

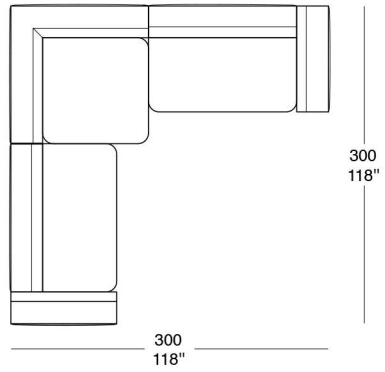

MOR 234

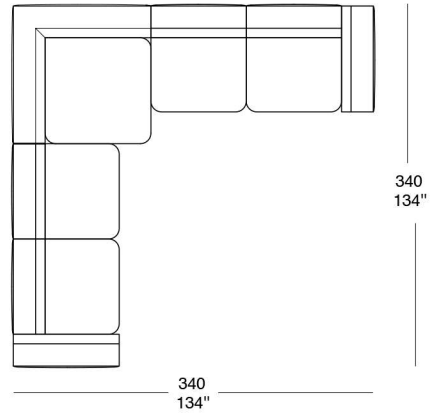

MOR 235

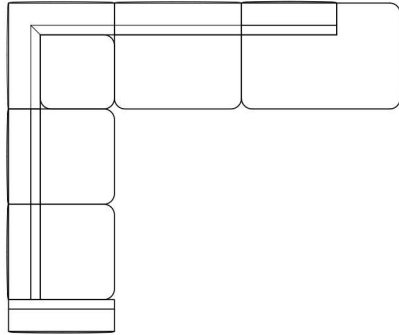

370
146"

MOR 236

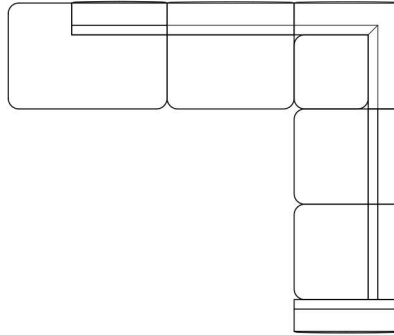

370
146"

310
122"

MOR 237

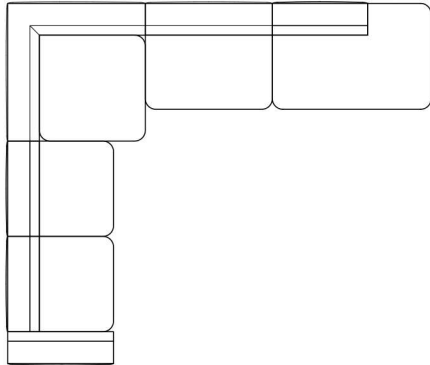

400
157"

MOR 238

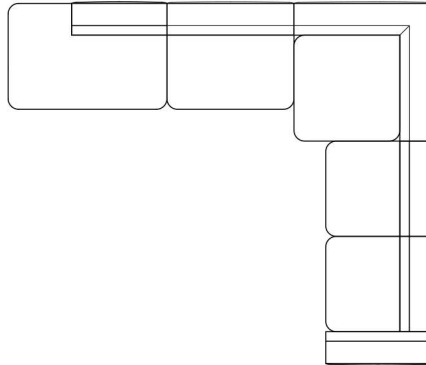

400
157"

340
134"

MOR 239

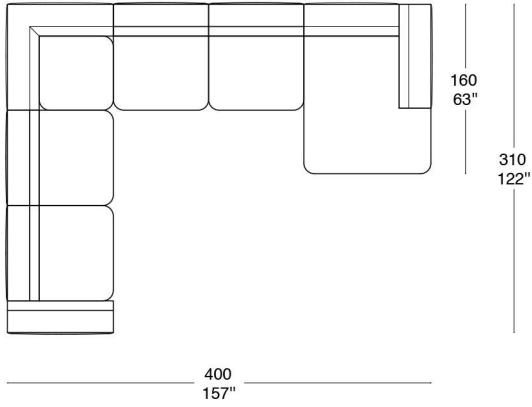

MOR 240

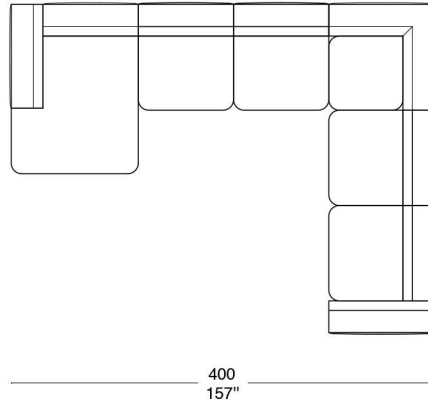

MOR 241

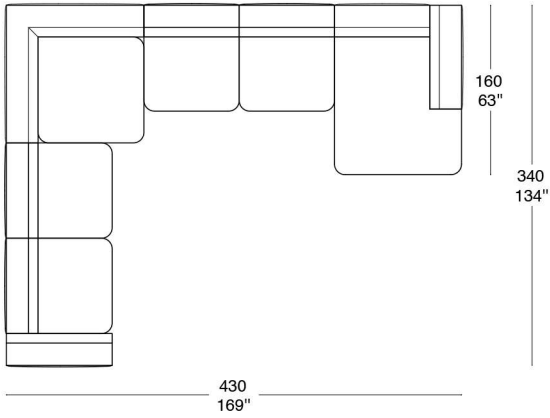

MOR 242

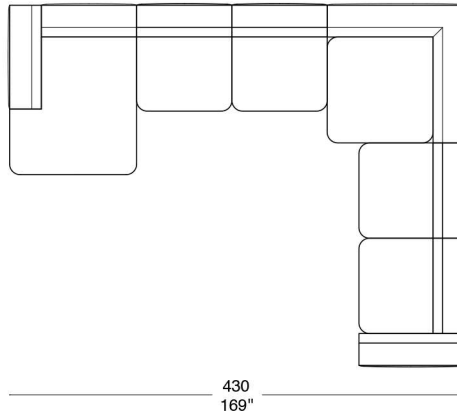

MOR 243

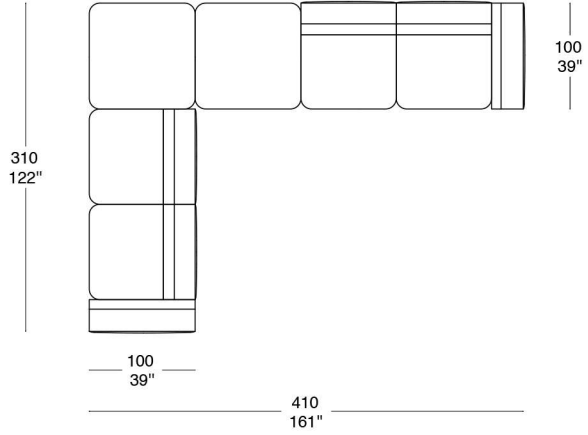

MOR 244

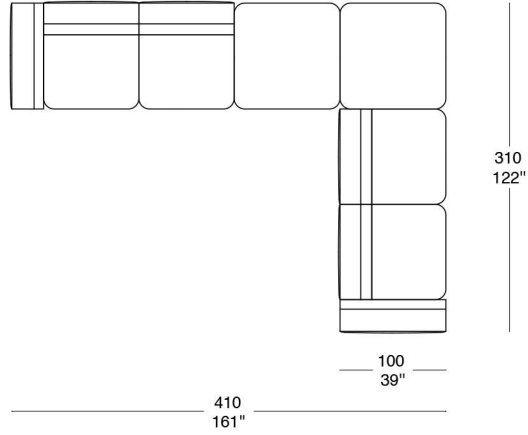

MOR 245

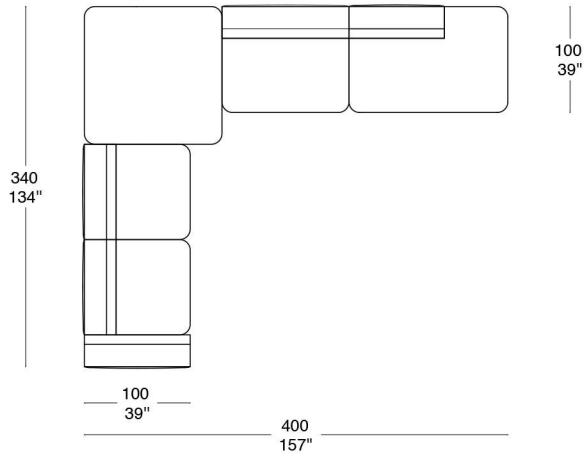

MOR 246

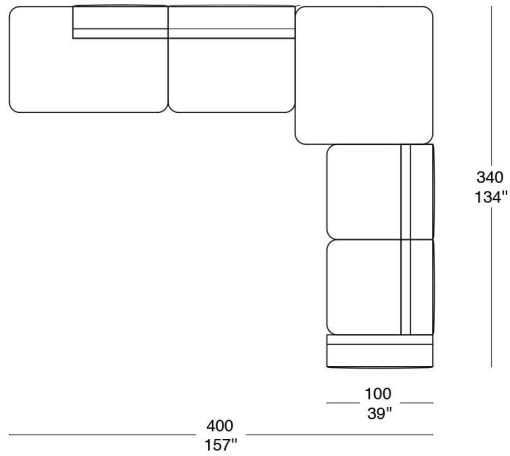

MOR 247

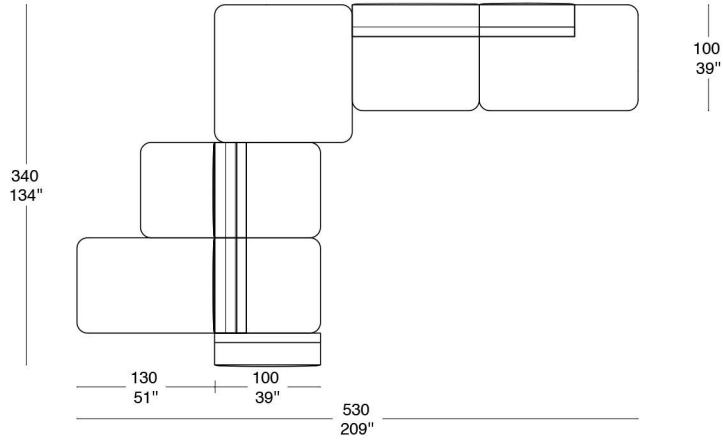

MOR 248

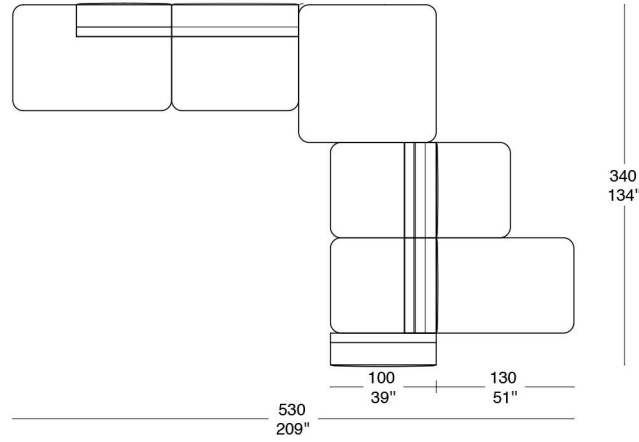

MOR 249

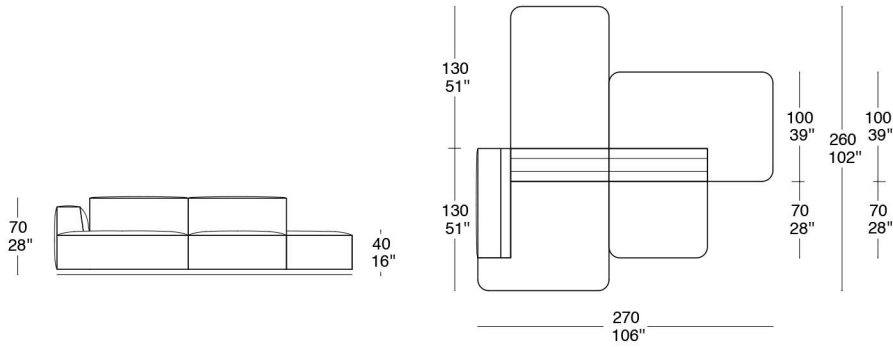

MOR 250

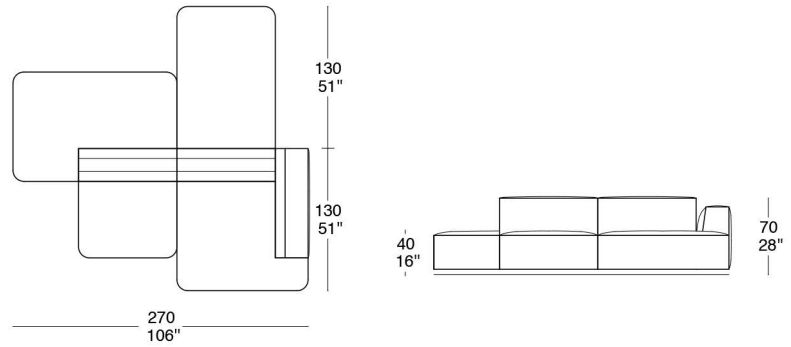



SOVEREIGN

I N T E R I O R S